



Qualität von Anfang an.

Technische Daten

BAUFORM

2-teilige Körperkonstruktion (verschraubt)

ANSCHLUß

Innengewinde: 1/2" ... 2" (DIN 2999)

EINBAULAGE

Waagrecht und Senkrecht, Durchflußrichtung beachten.

DURCHFLUSSMEDIUM

Nur für flüssige Medien.

MEDIUMDRUCK

PN16

TEMPERATUR

-25°C ... +180°C

WERKSTOFFE

Gehäuse:	Edelstahl 1.4408
Deckel:	Edelstahl 1.4408
Sitzdichtung:	metallisch
Stopfendichtung:	PTFE
Deckeldichtung:	PTFE

Alle Angaben sind freibleibend und unverbindlich!

Specification

DESIGN

Body consists of two screwed parts

CONNECTION

female thread: 1/2" ... 2" (DIN 2999)

MOUNTING POSITION

Horizontal and vertical, please refer to flow direction.

MEDIA

Only for liquid media.

PRESSURE RANGE

PN16

TEMPERATURE RANGE

-25°C ... +180°C

MATERIAL

Body:	Stainless steel 1.4408
Bonnet:	Stainless steel 1.4408
Seat seals:	metal
Plug seal:	PTFE
Cap seals:	PTFE

The above information is intended for guidance only and the company reserves the right to change any data herein without prior notice!

Artikel:

AR

Rückschlagklappe

PN16

Edelstahl



Type:

AR

Swing check valve

PN16

Stainless steel



Artikel- u. Bestellangaben: z.B. AR300025

= Rückschlagklappe, Edelstahl, metallisch dichtend, Innengewinde G1"

1.+ 2. Stelle Produkt	3.+ 4. Stelle Werkstoffe Gehäuse / Dichtung	5. Stelle Betätigung	6. Stelle Zusatzausstattung	7.+ 8. Stelle Anschlußgröße
AR = Rückschlagklappe	30 = Edelstahl / Edelstahl	0 = ohne	0 = ohne	21 = G 1/4 22 = G 3/8 23 = G 1/2 24 = G 3/4 25 = G 1 26 = G 1 1/4 27 = G 1 1/2 28 = G 2 29 = G 2 1/2 30 = G 3 31 = G 4

Ordering example: e.G. AR300025

= Swing check valve, stainless steel, metal-sealing, female B.S.P. thread, G1"

1.+ 2. Digit Product	3.+ 4. Digit Material Body / Seal	5. Digit Operation	6. Digit Option	7.+ 8. Digit Connection size
AR = Swing check valve	30 = Stainless steel / Stainless steel	0 = without	0 = no options	21 = G 1/4 22 = G 3/8 23 = G 1/2 24 = G 3/4 25 = G 1 26 = G 1 1/4 27 = G 1 1/2 28 = G 2 29 = G 2 1/2 30 = G 3 31 = G 4

Stückliste / Parts list :

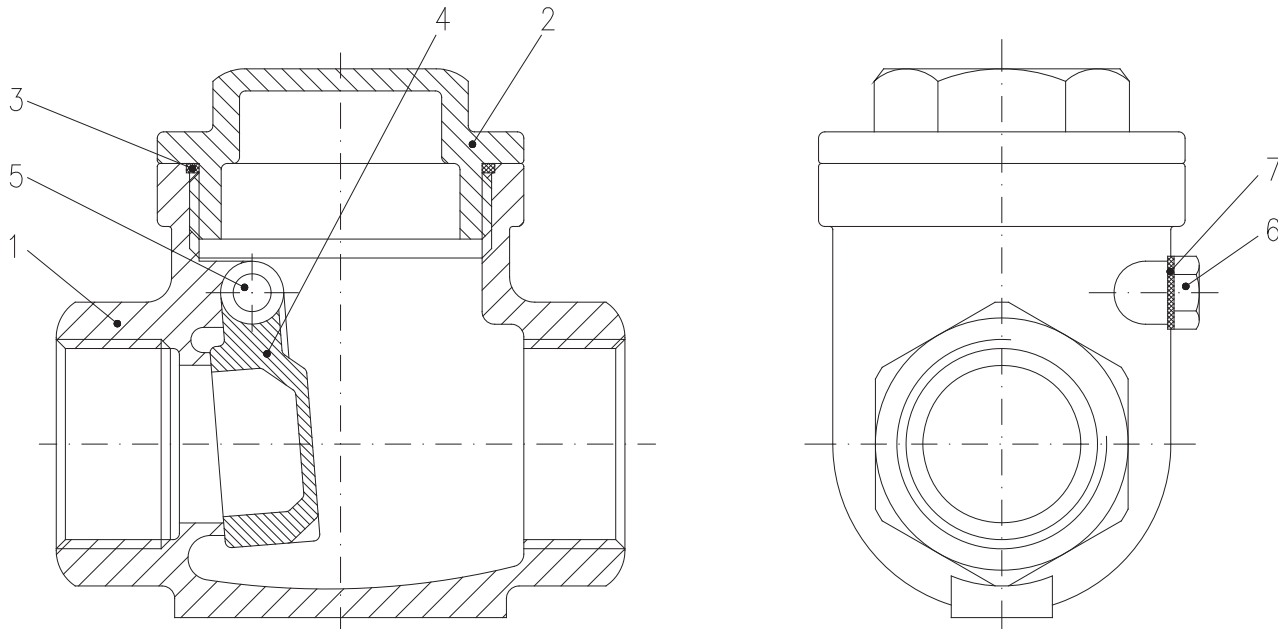

Pos.	Bezeichnung / Description		Material / Material	
1	Gehäuse	Body	Edelstahl 1.4408	Stainless steel 1.4408 (AISI 316)
2	Deckel	Cap	Edelstahl 1.4408	Stainless steel 1.4408 (AISI 316)
3	Deckeldichtung	Cap seal	PTFE	PTFE
4	Klappe	Flap	Edelstahl 1.4408	Stainless steel 1.4408 (AISI 316)
5	Achse	Shaft	Edelstahl	Stainless steel
6	Stopfen	Plug	Edelstahl	Stainless steel
7	Stopfendichtung	Plug seal	PTFE	PTFE



Abmessungen / Dimension :

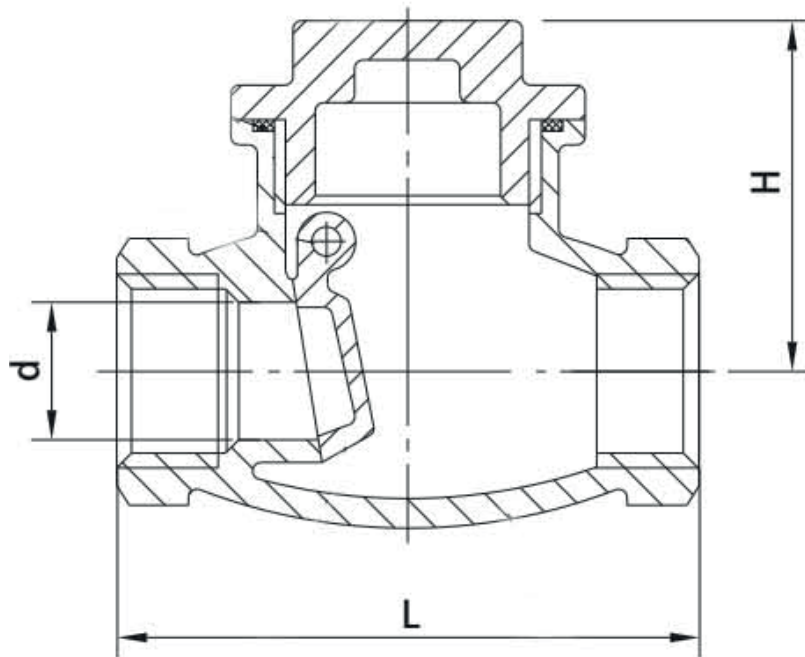

A	1/4	3/8	1/2	3/4	1	1 1/4	1 1/2	2	2 1/2	3	4
d	15	15	15	20	25	32	40	50	64	73	94
L	63	63	63	78	87	101	115	135	164	190	240
H	42	42	42	46	50	54	64	71	94	103	136

Hinweis

Bei den in dieser Dokumentation beschriebenen Produkten, in der von uns gelieferten Form, handelt es sich weder um Maschinen gemäß Artikel 2 Absatz a noch um unvollständige Maschinen gemäß Artikel 2 Absatz g im Sinne der Richtlinie 2006/42/EG über Maschinen.

Advice

The products described in this documentation in the conditions of our delivery are no machinery according to annex 2 paragraph a respectively no partly completed machinery according to annex 2 paragraph g of the directive 2006/42/EC on machinery.

