



Qualität von Anfang an.

## Technische Daten

### BAUFORM

Sitzventil mit Tellerdichtung.  
In Ruhestellung durch Federkraft gegen den Mediumstrom geschlossen. Automatisches Öffnen bei Überschreitung des eingestellten Abblasedruckes. Der Abblasedruck kann mittels der Stellschraube innerhalb des Druckbereichs eingestellt werden.

### WERKSTOFFE

Gehäuse: Edelstahl 1.4408  
Innenteile: Edelstahl  
Federhaube: Edelstahl  
Sitzdichtung: PTFE / FKM / EPDM  
(Andere auf Anfrage)

### ANSCHLUSS

- Innengewinde  
DIN ISO 228 T1: G $\frac{1}{2}$ " ... G3"  
NPT (ASME B1 20.1)  $\frac{1}{2}$ " - 2"
- Anschweißenden  
DIN 3239: DN15 ... DN50  
ISO 4200: DN15 ... DN80  
DIN 11850 Reihe 2: DN15 ... DN80
- Flanschanschluss  
EN 1092-1, PN40: DN15 ... DN50  
EN 1092-1, PN16: DN65 ... DN80  
Flansche PN16 - DN65 werden in 4-Loch-Ausführung geliefert!

### MEDIUMDRUCK (Öffnungsdruck)

siehe Tabelle

### MEDIUMTEMPERATUR

PTFE: -10°C ... +180°C  
FKM: -15°C ... +150°C  
EPDM: -20°C ... +130°C  
andere Temperaturen auf Anfrage.

### MEDIUM

Dampf, gasförmige oder flüssige Medien,  
abhängig vom Dichtungswerkstoff

### EINBAULAGE

Beliebig, vorzugsweise mit stehender Federhaube.

### ZUSATZAUSSTATTUNGEN

- Abgedichteter Federraum
- PTFE Dichtungen
- Druckluftfeder
- Metallfaltenbalg

Alle Angaben sind freibleibend und unverbindlich!

## Specification

### DESIGN

Spill valve with disc sealing.  
Normally closed by spring force against flow direction. Opens automatically, when the pressure exceed the adjusted blow-off pressure. The blow-off pressure can be adjusted by the set-screw inside of the pressure range.

### MATERIALS

Body: Stainless steel 1.4408  
Internal parts: Stainless steel  
Spring bonnet: Stainless steel  
Seat seal: PTFE / FKM / EPDM  
(Others on request)

### CONNECTION

- Threaded connection  
DIN ISO 228 T1: G $\frac{1}{2}$ " ... G3"  
NPT (ASME B1 20.1)  $\frac{1}{2}$ " - 2"
- Welded connection  
DIN 3239: DN15 ... DN50  
ISO 4200: DN15 ... DN80  
DIN 11850 Reihe 2: DN15 ... DN80
- Flanged connection  
EN 1092-1, PN40: DN15 ... DN50  
EN 1092-1, PN16: DN65 ... DN80  
Flanges PN16 - DN65 will be delivered in 4-hole execution!

### PRESSURE RANGE (Action pressure)

See table overleaf

### TEMPERATURE RANGE

PTFE: -10°C ... +180°C  
FKM: -15°C ... +150°C  
EPDM: -20°C ... +130°C  
other temperatures on request.

### MEDIUM

Steam, gases and liquids,  
depending on sealing material

### INSTALLATION

As desired, preferable with horizontal spring bonnet.

### OPTIONS

- Seald spring chamber
- PTFE seals
- air spring
- metal bellow

The above information is intended for guidance only and the company reserves the right to change any data herein without prior notice!

Artikel:  
**UV**

Überströmventil  
PN40 / PN16

Edelstahl



Type:  
**UV**

Spill valve  
PN40 / PN16

Stainless steel



## Artikel- u. Bestellangaben: z.B. UV330125

= Überströmventil, Edelstahl / FKM, Druckstufe 1, Innengewinde, G1

1. + 2. Stelle Produkt	3. + 4. Stelle Werkstoffe Gehäuse / Dichtung	5. + 6. Stelle Druckstufe	7. + 8. Stelle Anschlussgröße			
UV = Überströmventil	31 = Edelstahl / PTFE 33 = Edelstahl / FKM 34 = Edelstahl / EPDM	01 = Druckstufe 1 02 = Druckstufe 2 03 = Druckstufe 3  siehe Drucktabellen	Gewinde		Anschweißenden 62 = DN 15 63 = DN 20 64 = DN 25 65 = DN 32 66 = DN 40 67 = DN 50 68 = DN 65 69 = DN 80	Flanschanschluss 02 = DN 15 03 = DN 20 04 = DN 25 05 = DN 32 06 = DN 40 07 = DN 50 08 = DN 65 09 = DN 80
			ISO228	NPT		
			23 = 1/2"	53 = 1/2"		
			24 = 3/4"	54 = 3/4"		
			25 = 1"	55 = 1"		
			26 = 1 1/4"	56 = 1 1/4"		
			27 = 1 1/2"	57 = 1 1/2"		
			28 = 2"	58 = 2"		
			29 = 2 1/2"			
			30 = 3"			
9. ... 11. Stelle Optionen						
/AF = mit abgedichtetem Federraum						

## Ordering example: e.g. UV330125

= Spill valve, stainless steel / FKM, pressure range 1, B.S.P. thread, G1

1. + 2. Digit Product	3. + 4. Digit Material Body / seal	5. + 6. Digit Pressure range	7. + 8. Digit Connection size			
UV = Spill valve	31 = Stainless steel / PTFE 33 = Stainless steel / FKM 34 = Stainless steel / EPDM	01 = pressure range 1 02 = pressure range 2 03 = pressure range 3  see pressure charts	threaded connection		Welded connection 62 = DN 15 63 = DN 20 64 = DN 25 65 = DN 32 66 = DN 40 67 = DN 50 68 = DN 65 69 = DN 80	Flanged connection 02 = DN 15 03 = DN 20 04 = DN 25 05 = DN 32 06 = DN 40 07 = DN 50 08 = DN 65 09 = DN 80
			ISO228	NPT		
			23 = 1/2"	53 = 1/2"		
			24 = 3/4"	54 = 3/4"		
			25 = 1"	55 = 1"		
			26 = 1 1/4"	56 = 1 1/4"		
			27 = 1 1/2"	57 = 1 1/2"		
			28 = 2"	58 = 2"		
			29 = 2 1/2"			
			30 = 3"			
9. ... 11. Digit Options						
/AF = with sealed spring chamber						

## Druckbereiche [bar] / pressure range [bar]

Größe / size	1/2" DN15	3/4" DN20	1" DN25	1 1/4" DN32	1 1/2" DN40	2" DN50	2 1/2" DN65	3" DN80
Druckstufe 1 / pressure range 1	0,4 ... 12	0,4 ... 6	0,4 ... 3,5	0,3 ... 2	0,3 ... 1,5	0,3 ... 1	0,3 ... 3,5 <sup>1</sup>	0,3 ... 2,5 <sup>1</sup>
Druckstufe 2 / pressure range 2	6 ... 30	3 ... 16	1,5 ... 9,5	1 ... 5	0,8 ... 4	0,5 ... 2,5	3 ... 8 <sup>1</sup>	2 ... 6 <sup>1</sup>
Druckstufe 3 / pressure range 3	-	-	6 ... 25	4 ... 14	2,5 ... 12	2 ... 8	Anfrage / request	

## Einstellen des Abblasedrucks / set of the blow-off pressure

Mit der Einstellschraube kann der Abblasedruck innerhalb des Druckbereichs eingestellt werden.

### Erhöhung des Abblasedrucks:

Drehen Sie die Einstellschraube solange im Uhrzeigersinn, bis der gewünschte Abblasedruck erreicht ist.

### Verringerung des Abblasedrucks:

Drehen Sie die Einstellschraube solange gegen den Uhrzeigersinn, bis der gewünschte Abblasedruck erreicht ist.

Mit der Kontermutter die Einstellschraube gegen Verdrehen sichern.

The adjustment of the blow-off pressure takes place by turning the adjustment screw.

### Increase of the blow-off pressure:

Turn the adjustment screw clockwise until the desired blow-off pressure will be reached.

### Decrease of the blow-off pressure:

Turn the adjustment screw anti-clockwise until the desired blow-off pressure will be reached.

With the counter nut you can prevent the unintentional distort of the adjustment screw.

Abblasedruck verringern / decrease blow-off pressure

Abblasedruck erhöhen / increase blow-off pressure

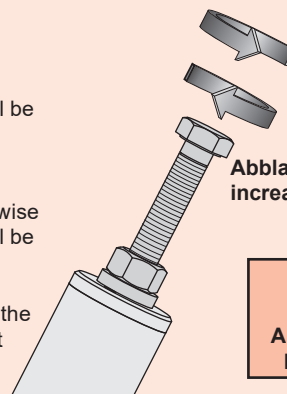

1 = Nur lieferbar in Verbindung mit Option abgedichteter Federraum  
available only in combination with option sealed spring chamber

# Abmessungen / Dimension

Gewindeanschluss  
Threaded connection

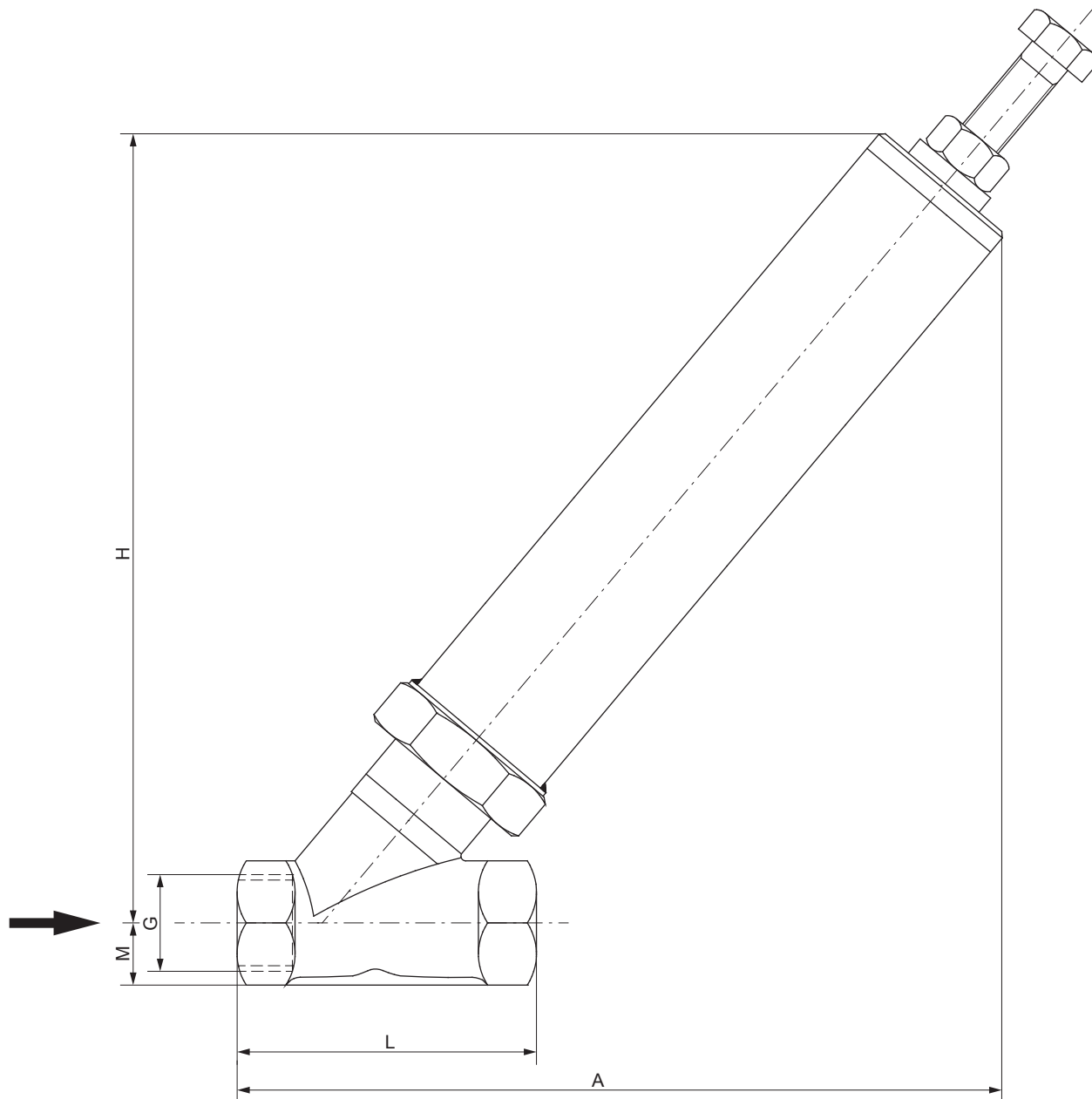

G	L	M	Druckstufe 1 / pressure range 1		Druckstufe 2 / pressure range 2		Druckstufe 3 / pressure range 3	
			A	H	A	H	A	H
1/2	65	12,5	178	186	178	186	-	-
3/4	75	15,5	174	177	174	177	-	-
1	90	18,5	181	178	181	178	261	272
1 1/4	110	23,0	194	187	194	187	273	280
1 1/2	120	26,5	200	193	200	193	276	282
2	150	33,5	219	201	219	201	295	290
2 1/2	180	42,5	307	310	307	310	-	-
3	200	50,0	335	317	335	317	-	-

Dok.-Nr.: KATUV-377 - 23.01.2025 - Änderung: Druckbereich angepasst!



# Abmessungen / Dimension

Anschweißenden  
Welded connection

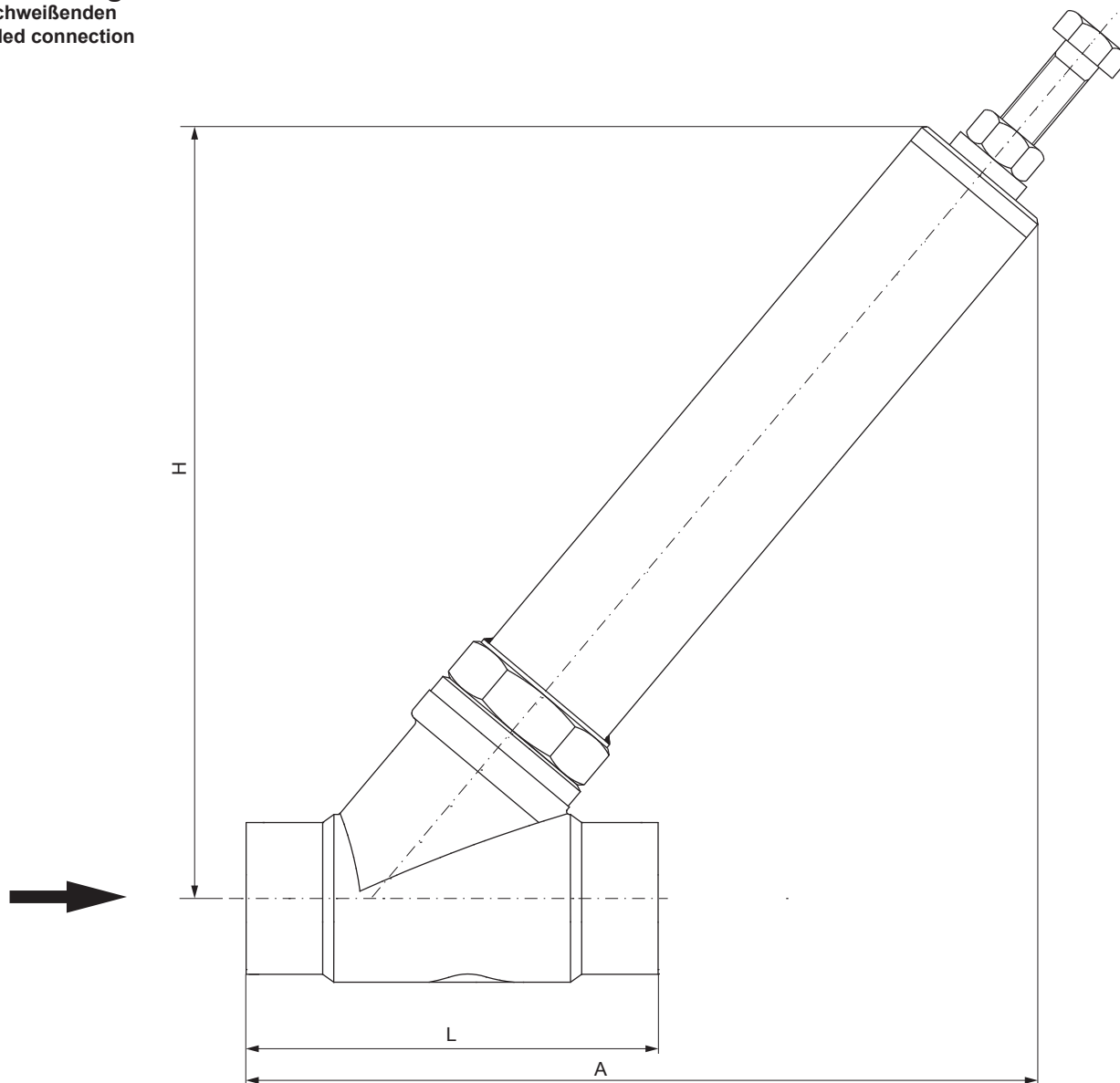

"A"-Anschweißenden DIN 3239 /  
"A"-welded connection DIN 3239

"L"-Anschweißenden ISO 4200 /  
"L"-welded connection ISO 4200

"M"-Anschweißenden DIN 11850-2 /  
"M"-welded connection DIN 11850-2

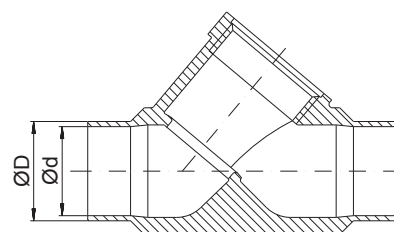
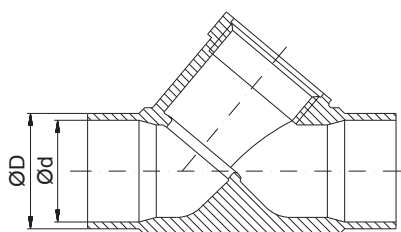
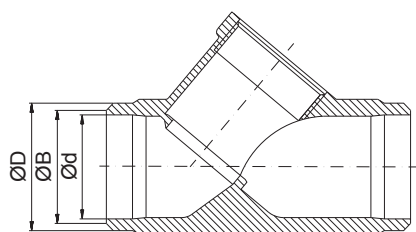

DN	L	DIN 3239 "A"			ISO 4200 "L"		DIN 11850-2 "M"		Druckstufe 1 / pressure range 1		Druckstufe 2 / pressure range 2		Druckstufe 3 / pressure range 3	
		ØD	ØB	Ød	ØD	Ød	ØD	Ød	A	H	A	H	A	H
15	65	24	22	17	21,3	18,1	19	16	178	186	178	186	-	-
20	75	30	28	22	26,9	23,7	23	20	174	177	174	177	-	-
25	90	36	34	28	33,7	29,7	29	26	181	178	181	178	261	272
32	110	45	41	35	42,4	38,4	35	32	194	187	194	187	273	280
40	120	52	49	43	48,3	44,3	41	38	200	193	200	193	276	282
50	150	62	61	54	60,3	55,1	53	50	219	201	219	201	295	290
65	205	-	-	-	76,1	70,3	70	66	327	310	327	310	-	-
80	220	-	-	-	88,9	83,1	85	81	355	317	355	317	-	-



# Abmessungen / Dimension

Flanschanschluss  
Flanged connection

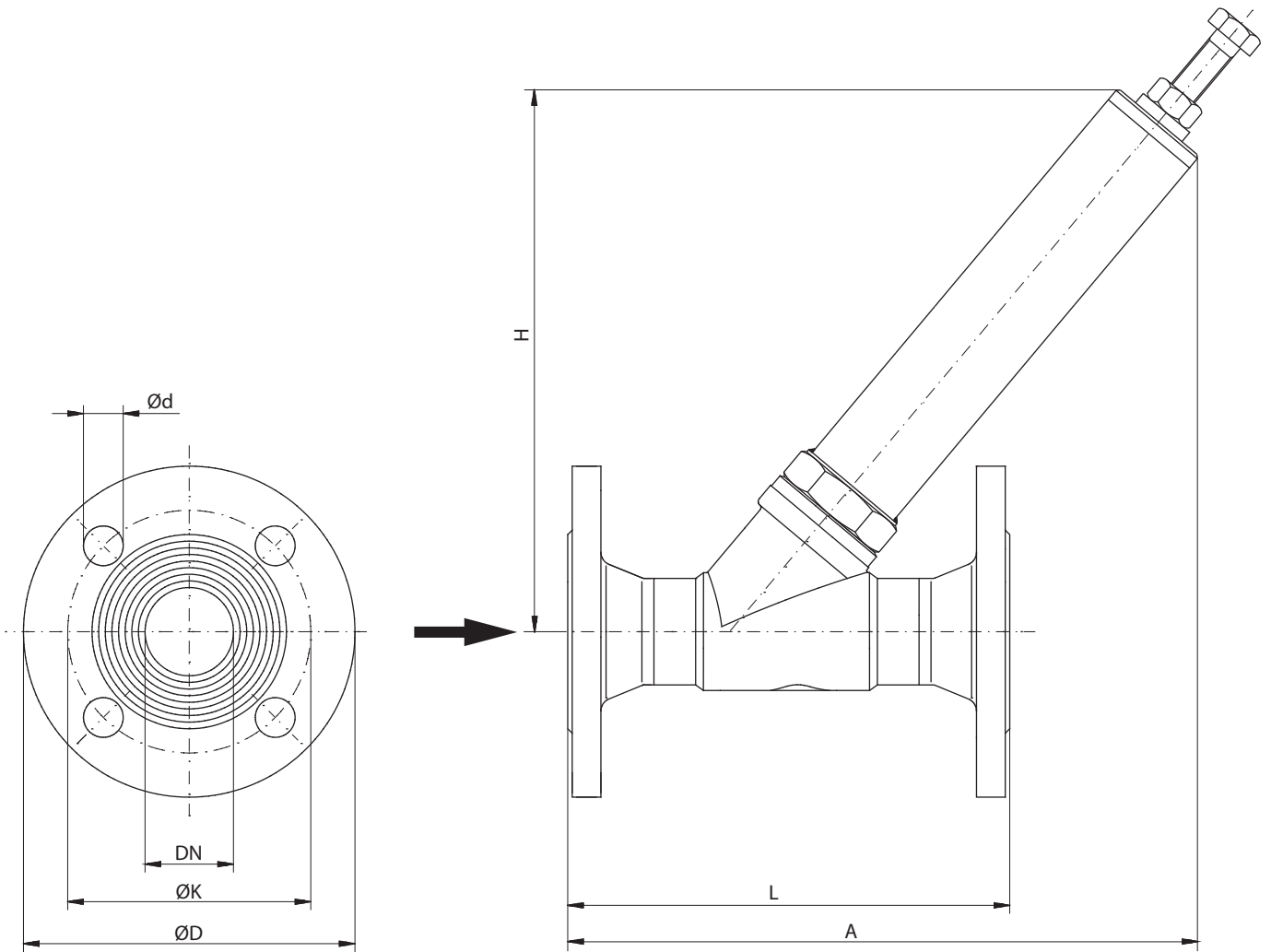

DN	L	EN 1092-1			Druckstufe 1 / pressure range 1		Druckstufe 2 / pressure range 2		Druckstufe 3 / pressure range 3	
		ØD	ØK	n x Ød	A	H	A	H	A	H
15	130	95	65	4 x 14	211	186	211	186	-	-
20	150	105	75	4 x 14	212	177	212	177	-	-
25	160	115	85	4 x 14	216	178	216	178	301	272
32	180	140	100	4 x 18	229	187	229	187	313	280
40	200	150	110	4 x 18	230	193	230	193	316	281
50	230	165	125	4 x 18	259	201	259	201	335	290
65 <sup>2</sup>	290	185	145	4 x 18	370	310	370	310	-	-
80	310	200	160	8 x 18	385	317	385	317	-	-

2 = Flansche PN16 - DN65 werden in 4-Loch-Ausführung geliefert! /  
Flanges PN16 - DN65 will be delivered in 4-hole execution!



# Stückliste / Parts list

Standardausführung

Standard version

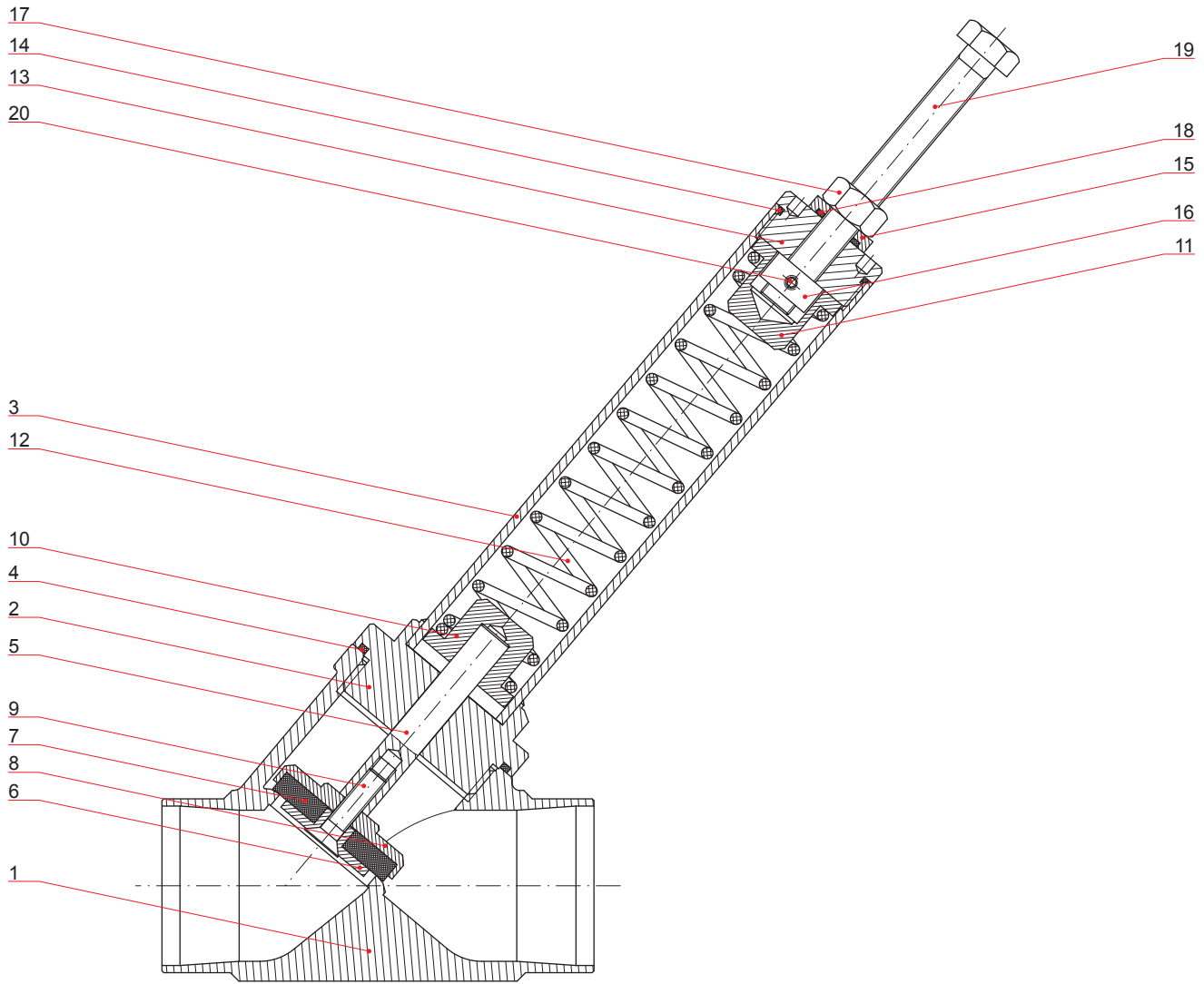

Pos.	Bezeichnung	Description	Material	Material
1	Schrägsitzgehäuse	Body		
2	Einschraubteil	Screw joint		
3	Hülse	Bushing		
4	Dichtring	Sealing ring		
5	Spindel	Stem		
6	Scheibe	Disc		
7	Sitzdichtung	Seat sealing		
8	Ventilteller	Valve disc		
9	Senkschraube	Screw		
10	Distanzstück	Spring bushing		
11	Distanzstück	Spring bushing		
12	Druckfeder	Spring		
13	Deckel	Cap		
14	O-Ring	O-ring		
15	Klemmscheibe	Disc		
16	Sondermutter	Special nut		
17	Sechskantmutter	Hexagon nut		
18	O-Ring	O-ring		
19	Sechskantschraube	Hexagon screw		
20	Gewindestift	Threaded pin		



# Stückliste / Parts list

Ausführung mit abgedichtetem Federraum (Option)

Version with sealed spring chamber (option)

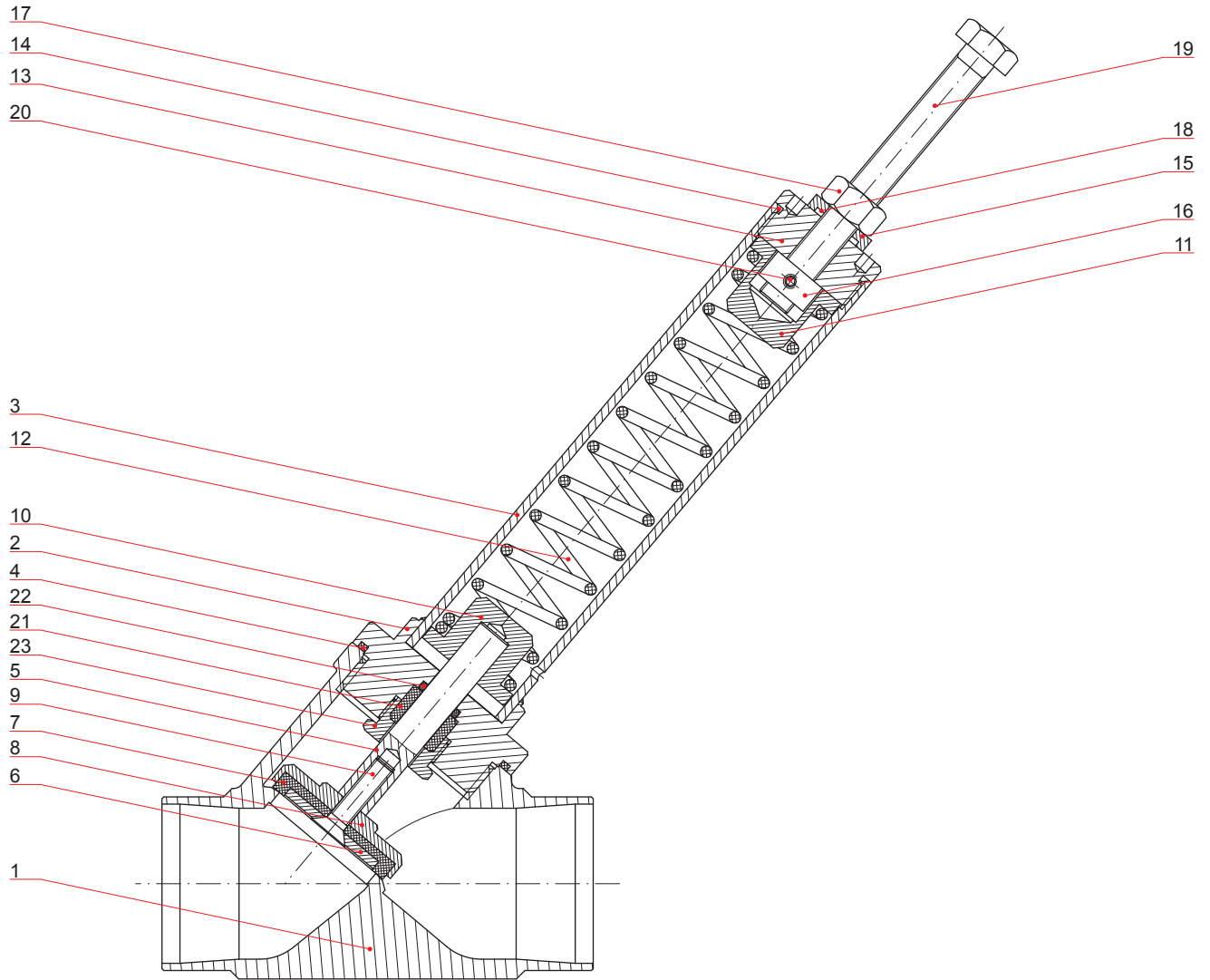

Pos.	Bezeichnung	Description	Material	Material
1	Schrägsitzgehäuse	Body		
2	Einschraubteil	Screw joint		
3	Hülse	Bushing		
4	Dichtring	Sealing ring		
5	Spindel	Stem		
6	Scheibe	Disc		
7	Sitzdichtung	Seat sealing		
8	Ventilteller	Valve disc		
9	Senkschraube	Screw		
10	Distanzstück	Spring bushing		
11	Distanzstück	Spring bushing		
12	Druckfeder	Spring		
13	Deckel	Cap		
15	Klemmscheibe	Disc		
16	Sondermutter	Spezial nut		
17	Sechskantmutter	Hexagon nut		
18	O-Ring	O-ring		
19	Sechskantschraube	Hexagon screw		
20	Gewindestift	Threaded pin		
21	Abstreifer und Nutring	Lip seal		
22	Führung	Guide ring		
23	Verschraubung	Screw joint		

Dok.-Nr.: KATUV-777 - 23.01.2025 - Änderung: Druckbereich angepasst!

