

## Technische Daten

### BAUFORM

1-teiliges Zentriergehäuse, mit auswechselbarer Manschette zum Einklemmen zwischen zwei Flansche nach **EN 1092-1 Typ 11 Form B (PN10 oder PN16) oder (ANSI 150 (nur WA))**; andere auf Anfrage.

Mit DVGW-Zulassung für Trinkwasser.

### PRÜFGRUNDLAGEN

DIN EN 1074-1:07/2000  
DIN EN 1074-2:07/2004  
DVGW W 363 (P)

### BAULÄNGE

Nach EN 558-1 Reihe 20.

### BETÄTIGUNG

90°-Drehung des Handhebels, mit 10 Einrastmöglichkeiten und Stellungsanzeige.

### ANSCHLUß<sup>1</sup>

Flansch DN50 ... DN300  
Größere Nennweiten auf Anfrage.

### BETRIEBSDRUCK

Artikel **WA / WM** (zwischen 2 Flanschen)  
max. 16bar

Artikel **WM** (als Endklappe)  
max. 10bar

### MEDIUMTEMPERATUR

-20°C ... +120°C  
(p<sub>max.</sub> = 10bar)  
andere auf Anfrage

### WERKSTOFFE

Gehäuse: GG-25, GGG-40  
blau RAL 5017  
Scheibe: Edelstahl 1.4408  
Wellendichtung: NBR / POM  
Welle: Edelstahl 1.4401  
Manschette: EPDM  
Handhebel: Sphäroguss, lackiert

### ZUSATZAUSSTATTUNG

Pneumatischer oder elektrischer Schwenkantrieb, elektrische Stellungsanzeige, Handhebel stufenlos verstellbar.

Alle Angaben sind freibleibend und unverbindlich!

## Specification

### DESIGN

Body consists of 1 part, with exchangeable seat to be mounted between two flanges acc. to **EN 1092-1 Typ 11 Form B (PN10 or PN16) or (ANSI 150 (only WA))**; others on request. With DVGW-approval for drinking water.

### BASIS OF TYPE EXAMINATION

DIN EN 1074-1:07/2000  
DIN EN 1074-2:07/2004  
DVGW W 363 (P)

### FACE TO FACE LENGTH

Acc. to EN 558-1 row 20.

### OPERATION

Rotation of the handle through 90°, with 10 snap-in positions and optical position indicator.

### CONNECTION<sup>1</sup>

Flange DN50 ... DN300  
Bigger sizes on request.

### PRESSURE RANGE

Type **WA / WM** (between 2 flanges)  
max. 16bar

Type **WM** (dead end service)  
max. 10bar

### TEMPERATURE RANGE

-20°C ... +120°C  
(p<sub>max.</sub> = 10bar)  
others on request

### MATERIALS

Body: GG-25, GGG-40  
blue RAL 5017  
Disc: Edelstahl 1.4408  
Stem seal: NBR / POM  
Stem: Stainless steel 1.4401  
Seat: EPDM  
Handle: Spheroidal cast iron, painted

### OPTIONS

Pneumatic or electric actuator, electric position indicator, handle lockable in all positions.

The above information is intended for guidance only and the company reserves the right to change any data herein without prior notice!

Artikel:  
**WA / WM**

Absperrklappe  
PN 10/16

GG-25, GGG-40



Type:  
**WA / WM**

Butterfly valve  
PN 10/16

GG-25, GGG-40

1) Flansche PN16 - DN65 werden in 4-Loch-Ausführung geliefert! / Flanges PN16 - DN65 will be delivered in 4-hole execution!



## Artikel- u. Bestellungenaben: z.B. WA534610

= Absperrklappe mit DVGW-Zulassung, GG-25, Edelstahl 1.4408, EPDM, DN100

1. + 2. Stelle Produkt	3. Stelle Gehäuse	4. Stelle Scheibe	5. Stelle Manschette	6. Stelle Zusatzausstattung	7. + 8. Stelle Anschlußgröße
<b>WA</b> = Absperrklappe, Zentriergehäuse <b>WM</b> = Absperrklappe, Anflanschgehäuse	<b>5</b> = GG-25 / GGG-40	<b>3</b> = Edelstahl 1.4408	<b>4</b> = EPDM	<b>6</b> = DVGW	<b>07</b> = DN 50 <b>08</b> = DN 65 <b>09</b> = DN 80 <b>10</b> = DN 100 <b>11</b> = DN 125 <b>12</b> = DN 150 <b>13</b> = DN 200 <b>14</b> = DN 250 <b>15</b> = DN 300

## Ordering example: e.g. WA534610

= Butterfly valve with DVGW-approval, GG-25, Stainless steel 1.4408, EPDM, DN100

1. + 2. Digit Product	3. Digit Body	4. Digit Disc	5. Digit Seat	6. Digit Options	7. + 8. Digit Connection size
<b>WA</b> = Butterfly valve Wafer type <b>WM</b> = Butterfly valve LUG-type	<b>5</b> = GG-25 / GGG-40	<b>3</b> = Stainless steel 1.4408	<b>4</b> = EPDM	<b>6</b> = DVGW	<b>07</b> = DN 50 <b>08</b> = DN 65 <b>09</b> = DN 80 <b>10</b> = DN 100 <b>11</b> = DN 125 <b>12</b> = DN 150 <b>13</b> = DN 200 <b>14</b> = DN 250 <b>15</b> = DN 300

Wir empfehlen ab Nennweite DN250 die Verwendung eines Getriebes Art. SCxx. /  
We recommend the use of a worm gear Art. SCxx from nominal diameter DN250 upwards.

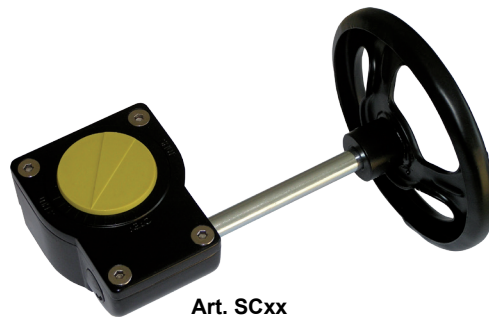

Art. SCxx

## Hinweis / Advice

Bei den in dieser Dokumentation beschriebenen Produkten, in der von uns gelieferten Form, handelt es sich weder um Maschinen gemäß Artikel 2 Absatz a noch um unvollständige Maschinen gemäß Artikel 2 Absatz g im Sinne der Richtlinie 2006/42/EG über Maschinen.

The products described in this documentation in the conditions of our delivery are no machinery according to annex 2 paragraph a respectively no partly completed machinery according to annex 2 paragraph g of the directive 2006/42/EC on machinery.



# Aufbau Art. WA / Construction Art. WA

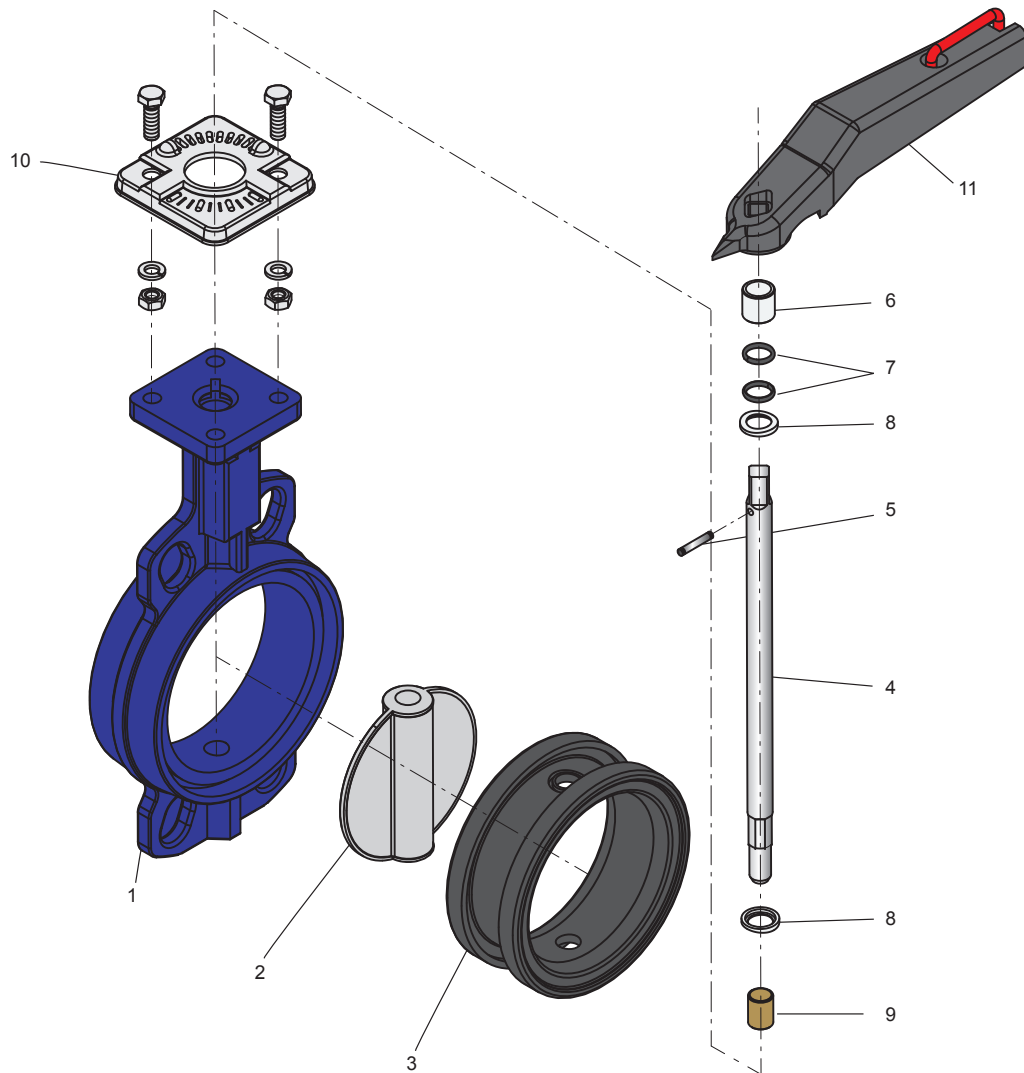

Pos.	Bezeichnung	Description	Material	Material
1	Gehäuse	Body	• GG-25 (DN50 ... DN150) • GGG-40 (DN200 ... DN300)	• GG-25 (DN50 ... DN150) • GGG-40 (DN200 ... DN300)
2	Scheibe	Disc	Edelstahl 1.4408	Stainless steel 1.4408
3	Manschette	Seat	EPDM	EPDM
4	Spindel	Stem	Edelstahl 1.4401	Stainless steel 1.4401
5	Stift	Pin	Edelstahl	Stainless steel
6	Buchse	Bush	POM	POM
7	O-Ring	O-ring	NBR	NBR
8	Verstärkungsring	Back-up ring	Kunststoff	Plastic
9	Buchse	Bush	Rotguss	Bronze
10	Rastscheibe	Snap-in disc	Stahl	Steel
11	Handhebel	Handle	Sphäroguss, lackiert	Spheroidal cast iron, painted

Dok-Nr.: KAT-WA-DVGW -3/6 - 108.03.2017 - Änderung:



# Aufbau Art. WM / Construction Art. WM

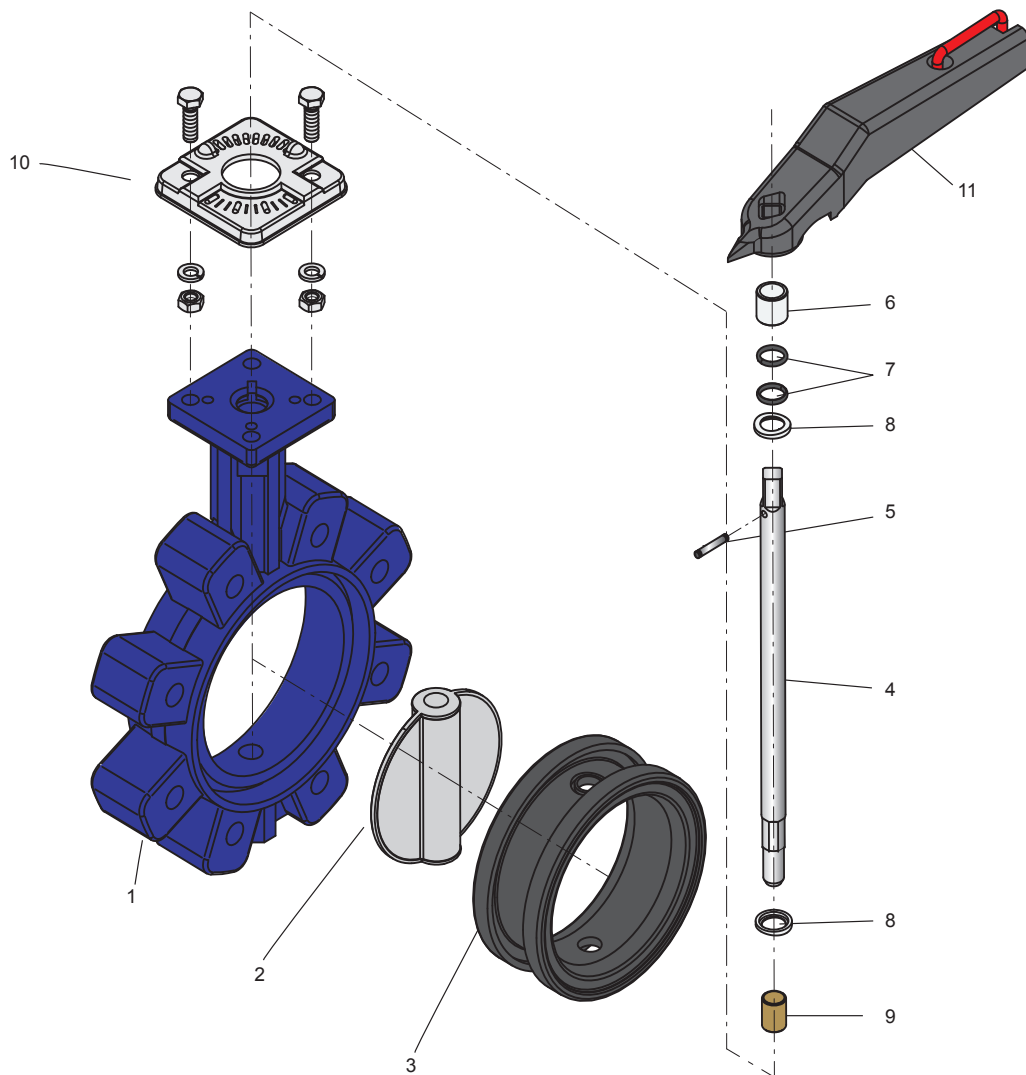

Pos.	Bezeichnung	Description	Material	Material
1	Gehäuse	Body	GGG-40	GGG-40
2	Scheibe	Disc	Edelstahl 1.4408	Stainless steel 1.4408
3	Manschette	Seat	EPDM	EPDM
4	Spindel	Stem	Edelstahl 1.4401	Stainless steel 1.4401
5	Stift	Pin	Edelstahl	Stainless steel
6	Buchse	Bush	POM	POM
7	O-Ring	O-ring	NBR	NBR
8	Verstärkungsring	Back-up ring	Kunststoff	Plastic
9	Buchse	Bush	Rotguss	Bronze
10	Rastscheibe	Snap-in disc	Stahl	Steel
11	Handhebel	Handle	Sphäroguss, lackiert	Spheroidal cast iron, painted



# Abmessungen Art. WA<sup>2</sup> / Dimensions Art. WA<sup>2</sup>

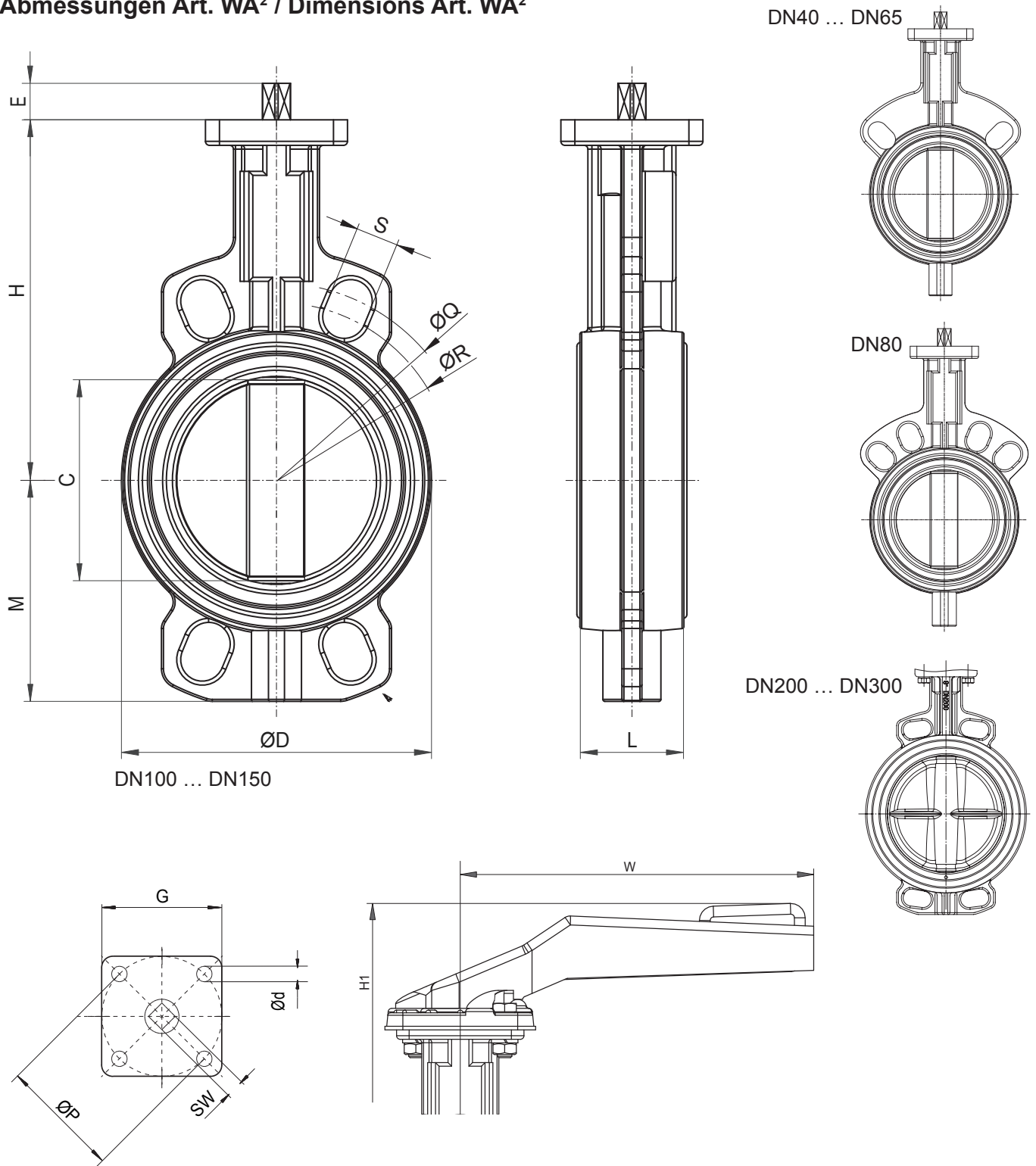

DN	C	L	H	M	H1	E	ØD	□G	ØP	ØQ	ØR	S	Ød	SW	W	kg
50	39	43	143	65	204	19	96	70	F07	124	114	23	10	11	200	3,0
65	55	46	155	71	216	19	110	70	F07	127	145	23	10	11	200	3,8
80	69	46	162	77	223	19	124	70	F07	159	150	23	10	11	200	4,0
100	91	52	181	107	242	19	148	70	F07	190,6	175	23	10	11	200	5,2
125	115	56	197	122	258	19	180	70	F07	216	210	27	10	14	250	7,3
150	140	56	210	140	271	19	208	70	F07	242	235	24	10	14	250	8,2
200	186	60	240	165	308	24	259	100	F10	298,5	290	27	12	17	355	13,5
250	239	68	286	201	354	24	320	100	F10	362	350	27	12	19	355	21,2
300	288	78	309	234	377	24	370	100	F10	431,8	400	29	12	22	355	32,5

2) Flansche PN16 - DN65 werden in 4-Loch-Ausführung geliefert! / Flanges PN16 - DN65 will be delivered in 4-hole execution!

Dok-Nr.: KAT-WA-DVGW - 516 - 108.03.2017 - Änderung:



# Abmessungen Art. WM<sup>3</sup> / Dimensions Art. WM<sup>3</sup>

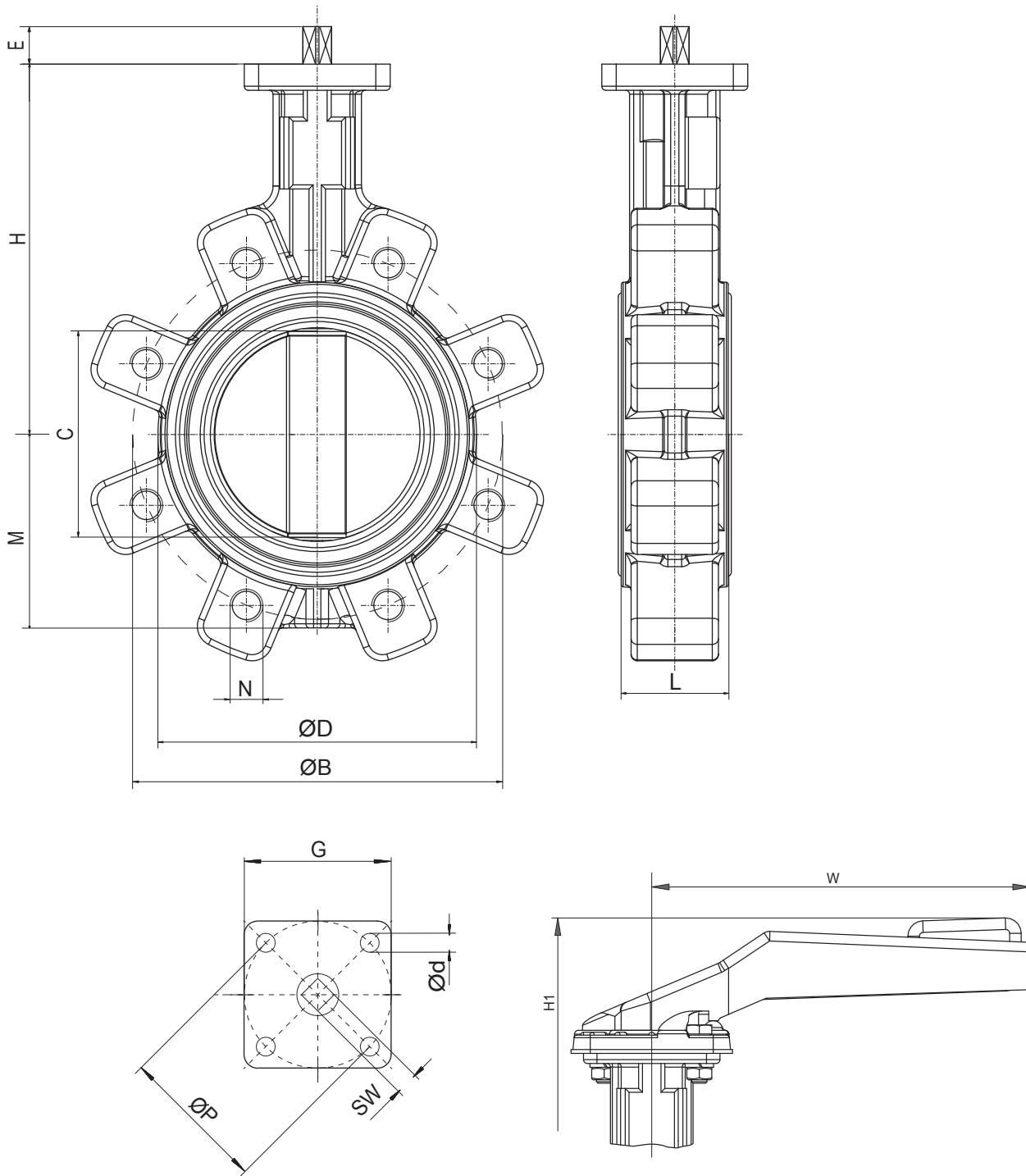

DN	C	L	H	M	H1	E	□G	ØP	Ød	ØD	SW	N	PN 16 n	ØB	W	kg
50	39	43	143	65	204	19	70	F07	10	96	11	M16	4	125	200	3,4
65	55	46	155	71	216	19	70	F07	10	110	11	M16	4	145	200	4,0
80	69	46	162	77	223	19	70	F07	10	124	11	M16	8	160	200	4,5
100	91	52	181	89	242	19	70	F07	10	148	11	M16	8	180	200	7,6
125	115	56	197	112	258	19	70	F07	10	180	14	M16	8	210	250	9,5
150	140	56	210	123	271	19	70	F07	10	208	14	M20	8	240	250	10,4
200	186	60	240	150	308	24	100	F10	12	259	17	M20	12	295	355	17,5
250	239	68	286	179	354	24	100	F10	12	320	19	M24	12	355	355	26,5
300	288	78	309	216	377	24	100	F10	12	370	22	M24	12	410	355	43,5

3) Flansche PN16 - DN65 werden in 4-Loch-Ausführung geliefert! / Flanges PN16 - DN65 will be delivered in 4-hole execution!